

# Licensing opportunity

## Sprayer for target application of phytopharmaceutical preparations in permanent crops

### Field of use

Plant protection – target spraying in permanent crops

### Current state of technology

Fully developed method (TRL 9)

### Patent status

Granted EPO patent valid in Germany, Italy, France, Slovenia and United Kingdom (EP2277376B1, pub. 13.08.2014)

### Publication

OSTERMAN, Aljaž, GODEŠA, Tone, HOČEVAR, Marko, ŠIROK, Brane, STOPAR, Matej. Real-time positioning algorithm for variable-geometry air-assisted orchard sprayer. *Computers and electronics in agriculture*, ISSN 0168-1699. [Print ed.], 2013, vol. 98, pg. 175-182.

### Applicant

Kmetijski inštitut Slovenije

### Inventors

JEJČIČ Viktor, HOČEVAR Marko, GODEŠA Tone, HERAKOVIČ Niko

### Reference

P-2009-1

### Contact

Technology Transfer Office:  
Nina Tomić  
nina.tomic@kis.si

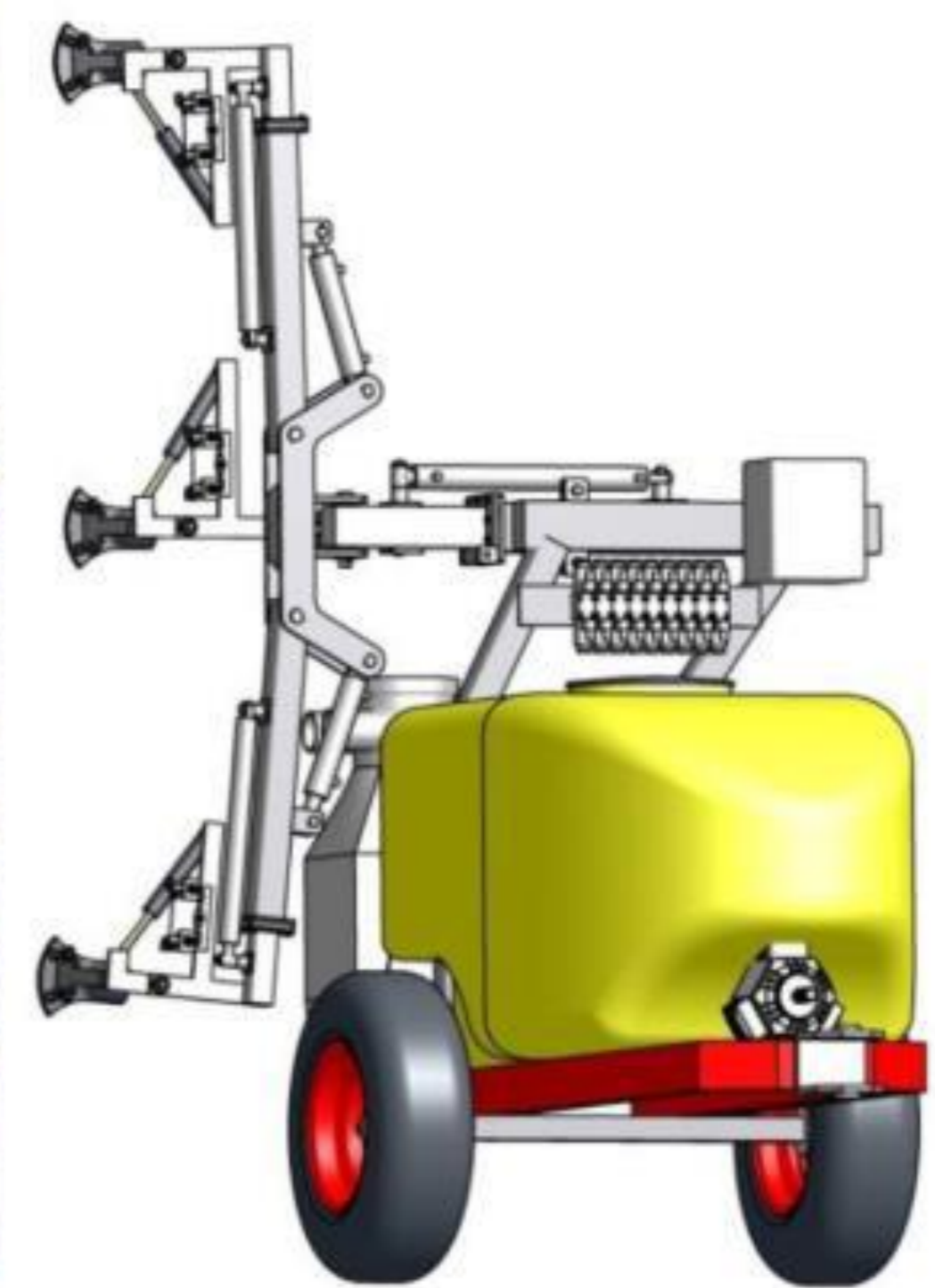

### Prior Art

Known sprayers of this type are formed as agricultural tractor attachments, on which at least one sprayer assembly of an optional known variant is mounted. Direction of spraying is set prior to spraying based on the average size and shape of plant crowns. When driving through a permanent crop, the tractor driver manually changes the quantity of the preparation as he progresses based on the changed density of plant crowns. A drawback of this solution lies in that the tractor driver must be constantly attentive to manually adapt the quantity and direction of spraying together with proper and safe driving. It can therefore not be expected from the driver to adequately meet the requirement for optimum spraying.

### Description of the invention

The subject of the present invention is a sprayer for targeted application of phytopharmaceutical preparations in permanent crops. The sprayer of the invention is preferably intended as an agricultural tractor attachment due to economic reasons, however, there is technically no obstacle for its being designed as an independent transport unit. The invention solves the design of a sprayer that would allow applying a predetermined optimum specific quantity of phytopharmaceutical preparations onto target surfaces of plants in permanent crops by simultaneously keeping the consumed quantity of phytopharmaceutical preparations at the lowest level possible.

### Main advantages

Invention enables precisely application of phytopharmaceutical preparations in accordance of the density of the crown of plant, the shape of the plant and the gaps in a permanent plantation (determined by means of machine vision, ultrasound, lidar or other sensing methods). Information from the sensors is given in real time to the spray nozzles that are activated in relation to the perceived target surface of the plant. Two prototype machines were designed and tested in exploitation, showing successful results with respect to the target application of phytopharmaceutical preparations.